

# **PCI-1757UP**

**24-channel Digital Input/Output  
Low Profile Universal PCI Card**

## **User Manual**

## **Copyright**

The documentation and the software included with this product are copyrighted 2004 by Advantech Co., Ltd. All rights are reserved. Advantech Co., Ltd. reserves the right to make improvements in the products described in this manual at any time without notice. No part of this manual may be reproduced, copied, translated or transmitted in any form or by any means without the prior written permission of Advantech Co., Ltd. Information provided in this manual is intended to be accurate and reliable. However, Advantech Co., Ltd. assumes no responsibility for its use, nor for any infringements of the rights of third parties, which may result from its use.

## **Acknowledgements**

PC-LabCard is a trademark of Advantech Co., Ltd.

IBM and PC are trademarks of International Business Machines Corporation.

MS-DOS and Windows are trademarks of Microsoft Corporation.

Intel and Pentium are trademarks of Intel Corporation

All other product names or trademarks are properties of their respective owners.

## **CE**

This product has passed the CE test for environmental specifications when shielded cables are used for external wiring. We recommend the use of shielded cables. This kind of cable is available from Advantech. Please contact your local supplier for ordering information.

Part No. 2003175701

2nd Edition

Printed in Taiwan

February 2005

## **Product Warranty (2 years)**

Advantech warrants to you, the original purchaser, that each of its products will be free from defects in materials and workmanship for two years from the date of purchase.

This warranty does not apply to any products which have been repaired or altered by persons other than repair personnel authorized by Advantech, or which have been subject to misuse, abuse, accident or improper installation. Advantech assumes no liability under the terms of this warranty as a consequence of such events.

Because of Advantech's high quality-control standards and rigorous testing, most of our customers never need to use our repair service. If an Advantech product is defective, it will be repaired or replaced at no charge during the warranty period. For out-of-warranty repairs, you will be billed according to the cost of replacement materials, service time and freight. Please consult your dealer for more details.

If you think you have a defective product, follow these steps:

1. Collect all the information about the problem encountered. (For example, CPU speed, Advantech products used, other hardware and software used, etc.) Note anything abnormal and list any onscreen messages you get when the problem occurs.
2. Call your dealer and describe the problem. Please have your manual, product, and any helpful information readily available.
3. If your product is diagnosed as defective, obtain an RMA (return merchandise authorization) number from your dealer. This allows us to process your return more quickly.
4. Carefully pack the defective product, a fully-completed Repair and Replacement Order Card and a photocopy proof of purchase date (such as your sales receipt) in a shippable container. A product returned without proof of the purchase date is not eligible for warranty service.
5. Write the RMA number visibly on the outside of the package and ship it prepaid to your dealer.

## **Technical Support and Assistance**

- Step 1. Visit the Advantech web site at **[www.advantech.com/support](http://www.advantech.com/support)** where you can find the latest information about the product.
- Step 2. Contact your distributor, sales representative, or Advantech's customer service center for technical support if you need additional assistance. Please have the following information ready before you call:
  - Product name and serial number
  - Description of your peripheral attachments
  - Description of your software (operating system, version, application software, etc.)
  - A complete description of the problem
  - The exact wording of any error messages

## **Packing List**

Before setting up the system, check that the items listed below are included and in good condition. If any item does not accord with the table, please contact your dealer immediately.

- 1 x PCI-1757UP Card
- 1 x User Manual
- 1 x CD-ROM
- 1 x Normal Profile Replacement Bracket

## **Safety Precaution - Static Electricity**

Follow these simple precautions to protect yourself from harm and the products from damage.

1. To avoid electrical shock, always disconnect the power from your PC chassis before you work on it. Don't touch any components on the CPU card or other cards while the PC is on.
2. Disconnect power before making any configuration changes. The sudden rush of power as you connect a jumper or install a card may damage sensitive electronic components.

# Contents

<b>Chapter 1</b>	<b>General Information .....</b>	<b>2</b>
1.1	Introduction .....	2
1.2	Numbering Convention .....	2
1.3	Features .....	3
1.4	Specifications .....	4
<b>Chapter 2</b>	<b>Installation .....</b>	<b>8</b>
2.1	Initial Inspection .....	8
2.2	Unpacking .....	8
2.3	Jumper & Switch Settings .....	8
	Figure 2.1:Locations of Connectors and Jumpers .....	9
2.3.1	Setting the BoardID Switch (SW1) .....	10
	Table 2.1:BoardID Setting .....	10
2.3.2	Set Ports as Input or Output (SW2) .....	10
	Figure 2.2:SW2 Settings .....	10
	Table 2.2:Input or Output Ports Setting .....	10
2.3.3	Output Signal at Hot Reset Setting (JP1) .....	11
	Table 2.3:Hot Reset Mode Setting .....	11
2.3.4	Select PC7 or 5V on Pin24 (JP2) .....	12
2.4	Pin Assignments .....	13
2.5	Installation Instructions .....	14
<b>Chapter 3</b>	<b>Operation .....</b>	<b>16</b>
3.1	Overview .....	16
3.2	Digital I/O Ports .....	16
3.2.1	Introduction .....	16
3.2.2	8255 Mode 0 .....	16
3.2.3	Input/Output Control .....	17
	Table 3.1:Bit Map of Port Configuration Register .....	17
3.2.4	Initial Configuration .....	18
3.3	Interrupt Function .....	18
3.3.1	Interrupt Function of the D I/O Signals .....	18
	Table 3.2:Interrupt Control Register Bit Map .....	18
3.3.2	Interrupt Source Control .....	19
	Figure 3.1:Interrupt Sources .....	19
	Table 3.3:Interrupt Mode Bit Values .....	19
3.3.3	Interrupt Triggering Edge Control .....	19
	Table 3.4:Triggering Edge Control Bit Values .....	19
3.3.4	Interrupt Flag Bit .....	20
	Table 3.5:Interrupt Flag Bit Values .....	20
3.4	BoardID Switch .....	20
	Table 3.6:BoardID Register .....	20
<b>Appendix A</b>	<b>Register Format.....</b>	<b>22</b>



## **General Information**

This chapter introduces PCI-1757UP and provides detailed specifications.

Sections include:

- Introduction
- Numbering Convention
- Features
- Specifications

# Chapter 1 General Information

## 1.1 Introduction

---

PCI-1757UP is a 24-bit DI/O card with PCI bus. It provides you with 24 bits of parallel digital input/output, and emulates mode 0 of the 8255 PPI chip, but the buffered circuits offer a higher driving capability than the 8255.

The card emulates one 8255 PPI chips to provide 24 DI/O bits. The I/O bits are divided into three 8-bit I/O ports: A0, B0 and C0. You can configure each port as either input or output via software. The dual interrupt handling capability provides users the flexibility to generate interrupts to a PC. A pin in the connector can output a digital signal simultaneously with the card's generating an interrupt.

This card uses a DB 25-pin connector for easy and reliable connections to field devices.

One feature gives PCI-1757UP a practical advantage in an industrial setting. When the system is hot reset (the power is not turned off) the PCI-1757UP retains the last I/O port settings and output values if the user has set jumper JP1 to enable this feature. Otherwise, port settings and output values reset to their safe default state, or to the state determined by other jumper settings.

## 1.2 Numbering Convention

---

All numbers given in this manual are in decimal format unless specifically noted otherwise. In particular, where a register address is given as (Base + 32), the decimal number "32" should be added to the base value.



## 1.3 Features

---

- Low profile PCI card
- Universal PCI interface, acceptst 3.3 V and 5 V PCI slots
- 24 TTL level digital I/O lines
- Emulates mode 0 of 8255 PPI
- Buffered circuits provide higher driving capability
- Output status read-back
- I/O configured by software or onboard DIP switch
- Hot reset output memory keeps I/O settings and digital output states after hot reset
- BoardID DIP switch for multiple PCI-1757UP cards in one PC
- Digital inputs with interrupt capability
- D-SUB 25-pin connector

## 1.4 Specifications

---

### Digital Input

- **Logic High Voltage:** 2.0 V min.
- **Logic Low Voltage:** 0.80 V max.
- **Maximum Input Leakage Current:** 2 $\mu$ A

### Digital Output

- **Logic High Voltage:** 3.7 V min. @ 24mA (source)
- **Logic Low Voltage:** 0.5 V max. @ -24 mA (sink)

### Interrupt Source

- PC0, PC4

### General

- **Connector:** One D-SUB 25-pin female connector
- **Power Consumption:** 5 V @ 200 mA (Typical)
- **Operating Temperature:** 0 ~ 70° C (32 ~ 158 °F)
- **Storage Temperature:** -20 ~ 80° C (-4 ~ 176° F)
- **Humidity:** 5 ~ 95% non-condensing
- **Dimensions:** 119.91 x 64.41 mm (4.721" x 2.536") Low profile PCI MD1 card size.
- **I/O Channels:** 48 digital I/O lines
- **Programming Mode:** 8255 PPI mode 0





## Installation

This chapter provides information on installing your card and making jumper/switch configurations.

Sections include:

- Initial Inspection
- Unpacking
- Jumper and Switch Settings
- Pin Assignments
- Installation Instructions

# Chapter 2 Installation

## 2.1 Initial Inspection

---

Before starting to install PCI-1757UP, make sure there is no visible damage on the card. We carefully inspected the card both mechanically and electrically before shipment. It should be free of marks and in perfect order on receipt.

As you unpack PCI-1757UP, check for signs of shipping damage (damaged box, scratches, dents, etc.) If it is damaged or fails to meet its specifications, notify our service department or your local sales representative immediately. Also, call the carrier immediately and retain the shipping carton and packing materials for inspection by the carrier. We will then make arrangements to repair or replace the unit.

## 2.2 Unpacking

---

PCI-1757UP contains components that are sensitive and vulnerable to static electricity. Discharge any static electricity on your body to ground by touching the back of the system unit (grounded metal) before you touch the board.

Remove the PCI-1757UP card from its protective packaging by grasping the card's rear panel. Handle the card only by its edges to avoid static discharge which could damage its integrated circuits. Keep the antistatic package. Whenever you remove the card from the PC, please store the card in this package for its protection.

You should also avoid contact with materials that hold static electricity such as plastic, vinyl and styrofoam. Check the product contents inside the packing. There should be one card, one CD-ROM, an extra bracket and this manual. Make sure nothing is missing.

## 2.3 Jumper & Switch Settings

---

We designed PCI-1757UP with ease-of-use in mind. It is a Plug & Play card, i.e. the system BIOS assigns the system resources such as base address and interrupt automatically. The following section describes how to configure the card. You may want to refer to the figure below for help in identifying card components.

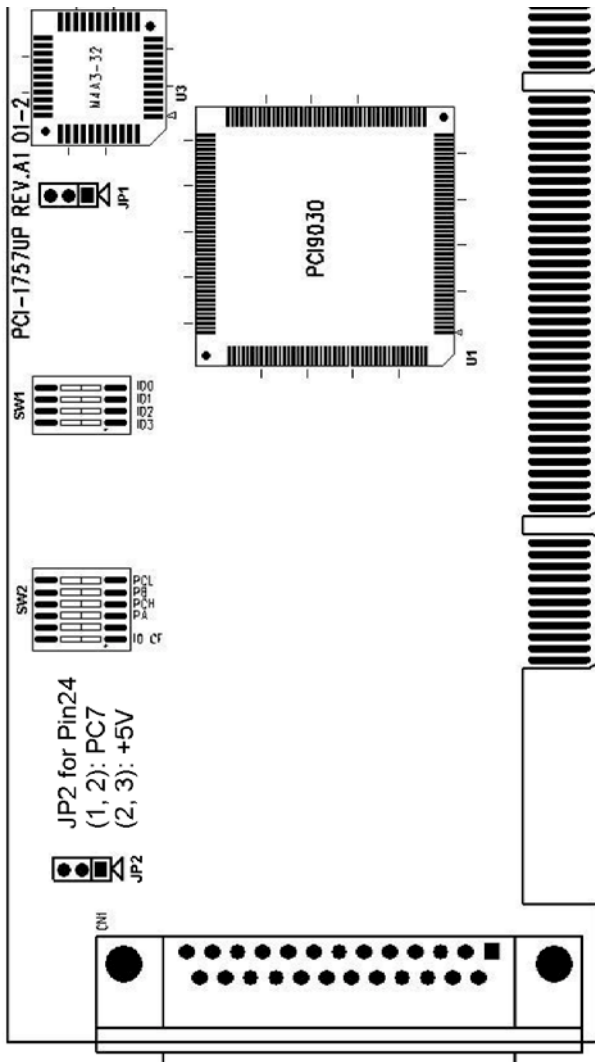

Figure 2.1: Locations of Connectors and Jumpers

### 2.3.1 Setting the BoardID Switch (SW1)

This section describes how to set the BoardID switch of PCI-1757UP. The figure and table below show the switch locations and how they give a unique identifier to the card.

**Table 2.1: BoardID Setting**

SW1	Position1	Position2	Position3	Position4
Board ID	ID3	ID2	ID1	ID0
0*	ON	ON	ON	ON
1	ON	ON	ON	OFF
2	ON	ON	OFF	ON
:	:	:	:	:
14	OFF	OFF	OFF	ON
15	OFF	OFF	OFF	OFF

\*Default Setting is 0.

### 2.3.2 Set Ports as Input or Output (SW2)

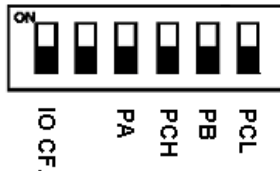

**Figure 2.2: SW2 Settings**

**Table 2.2: Input or Output Ports Setting**

Description	Switch 2	ON	OFF
IO CF.	SW2-1	HW	SW
-	SW2-2	-	-
PA	SW2-3	IN	OUT
PCL	SW2-4	IN	OUT
PB	SW2-5	IN	OUT
PCH	SW2-6	IN	OUT

\*Default setting is all positions off.





PCI-1757UP emulates one 8255 programmable peripheral interface (PPI) chip in mode 0, but with higher driving capability than a standard 8255 chip. Each of the 8255 chips has 24 programmable I/O pins that are divided into two 8-bit ports and two 4-bit ports, designated PA, PB PCL and PCH.

Each port can be programmed as an input or an output port. You can set the corresponding ports to be configurable as input or output ports by switch SW2 or software. When “IO CF.” position is “ON”, set the ports to be input or output ports by the software. Else, when “IO CF.” position is “Off”, you can set the ports by the switch SW2 directly. The position setting is “ON”, the corresponding port is input port; else position is “OFF”, the corresponding port is output port.

### 2.3.3 Output Signal at Hot Reset Setting (JP1)



As shown below, JP1 is used to set the output signal after a hot reset.

<i>Table 2.3: Hot Reset Mode Setting</i>	
<b>JP1</b>	<b>Output Signals Status after Hot Reset</b>
	Hot Reset Output Memory. Remember the last output signals and I/O settings before reset and keep these values on power up.
	Default Output Setting Clear the I/O configuration to default if hot reset.

*Note*                      *The reset must be a "hot" reset (power not disconnected) for enabled JP1 to return ports to their prior values. Otherwise, the card behaves as though JP1 was not enabled.*

### 2.3.4 Select PC7 or 5V on Pin24 (JP2)

5 V output can be output by setting JP2.

JP2	Power on configuration after hot reset
	Pin 24 is connected to 5V
	Pin 24 is for PC7( Default)

## 2.4 Pin Assignments

---

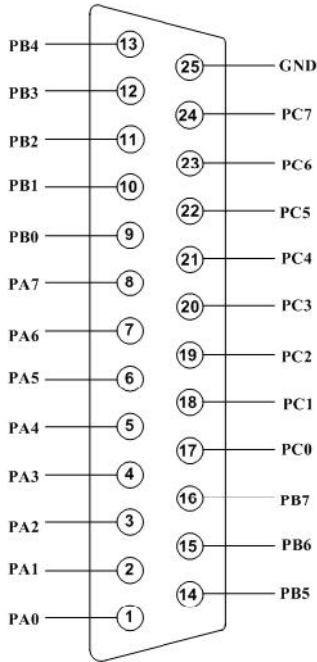

Description of pin use:

Mode	Description	Pin
PA0 ~ PA7	I/O pins of Port A	Pin 1~8
PB0 ~ PB7	I/O pins of Port B	Pin 9~16
PC0 ~ PC7	I/O pins of Port C	Pin 17~24
GND	Ground	Pin 25

## 2.5 Installation Instructions

---

PCI-1757UP can be installed in any PCI slot of the computer. However, refer to the computer user's manual to avoid any mistakes and danger before you follow the installation procedure below:

1. Turn off your computer and any accessories connected to the computer.

**Warning!**      *TURN OFF your computer power supply whenever you install or remove any card, or disconnect cables.*

2. Disconnect the power cord and any other cables from the back of the computer.
3. Remove the cover of the computer.
4. Select an empty PCI slot. Remove the screw that secures the expansion slot cover to the system unit. Save the screw to secure the interface card with the retaining bracket.
5. Carefully grasp the upper edge of PCI-1757UP. Align the hole in the retaining bracket with the hole on the expansion slot and align the gold striped edge connector with the expansion slot socket. Press the card into the socket gently but firmly. Make sure the card fits the slot tightly.
6. Secure PCI-1757UP by screwing the mounting bracket to the back panel of the computer.
7. Attach any accessories (25-pin cable, wiring terminal, etc.) to the card.
8. Replace the cover of your computer. Connect the cables you removed in step 2.
9. Turn the computer on.

## Operation

This chapter shows how to operate PCI-1757UP.

Sections include:

- Overview
- Digital I/O Ports
- Interrupt Function
- BoardID Switch

# Chapter 3 Operation

## 3.1 Overview

---

This chapter describes how to operate PCI-1757UP. The driver software provided allows a user to access all of the card's functions without register level programming. Please see the User's Manual for the driver bundled with this card for more information. For those who prefer to implement their own bit-level programming to drive the card's functions, information useful for making such a program is included in this chapter.

## 3.2 Digital I/O Ports

---

### 3.2.1 Introduction

PCI-1757UP emulates one 8255 programmable peripheral interface (PPI) chip in mode 0, but with higher driving capability than a standard 8255 chip. Each of the 8255 chips has 24 programmable I/O pins that are divided into three 8-bit ports, designated PA, PB and PC. Each port can be programmed as an input or an output port. The I/O pins in port A are designated PA0, PA1, ..., PA7; the pins in port B are designated PB0, PB1, ..., PB7, etc. These port names are used both in this manual and in the software library. Refer to Section 2.4, Pin Assignments.

### 3.2.2 8255 Mode 0

The basic functions of 8255 mode 0 include:

- Two 8-bit I/O ports - port A (PA) and port B (PB)
- Port C is divided into two nibble-wide (4-bit) I/O ports: PC upper and PC lower
- Any port can be used for either input or output.
- Output status can be read back.

### 3.2.3 Input/Output Control

A control word can be written to a port's configuration register (Base+3) to set the port as an input or an output port, unless the ports are set via the switch. Table 3-1 shows the format of a control word.

**Table 3.1: Bit Map of Port Configuration Register**

Bit	Description		
D0	Port C lower bits	0: output;	1: input
D1	Port B	0: output;	1: input
D2	Ignore		
D3	Port C higher bits	0: output;	1: input
D4	Port A	0: output;	1: input
D5	Ignore		
D6	Ignore		
D7	HW/SW	0: SW;	1: HW

**Note:** *A control word has no effect if the corresponding port is set as an output port by the SMD switch SW2. D7 is a read only bit for identifying the SMD switch SW2 position 1 is ON or OFF.*

*D7 = 0 means the I/O configuration is set by configuration register (SW); D7 = 1 means the I/O configuration is set by SMD switch SW2 (HW). When D7= 1, read the value of D4, D3, D1 and D0 mapping the SW2 location 3, 4, 5 and 6, respectively.*

**Warning!** *Before setting any port as an output port via software, make sure that a safe output value has also been set. An output voltage will appear at the pins immediately following the control word taking effect. If no output value was specified, the value will be indeterminate (either 0 or 1), which may cause a dangerous condition.*

### 3.2.4 Initial Configuration

The initial configuration of each port depends on the software or switch SW2 setting of each port as input or output port, and on the setting of the jumper JP1 for the hot reset type.

## 3.3 Interrupt Function

---

### 3.3.1 Interrupt Function of the D I/O Signals

Two I/O pins (PC0 and PC1) can be used to generate hardware interrupts. The interrupt control register can be programmed (Base + 32) to select the interrupt sources.

The "Interrupt Control Register" (Base + 32) controls the interrupt signal source, edge and flag. Table 3-2 shows the bit map of the interrupt control register. The register is a readable/writable register.

When writing to it, it is used as a control register, and when reading from it, it is used as a status register.

**Table 3.2: Interrupt Control Register Bit Map**

Bit#	D7	D6	D5	D4	D3	D2	D1	D0
	X	X	X	X	F	E	M1	M0

**M0 and M1:** "mode bits" of port 0

**E:** triggering edge control bits

**F:** flag bits

**X:** ignore



### 3.3.2 Interrupt Source Control

The "mode bits" in the interrupt control register determine the allowable sources of signals generating an interrupt. Bit 0 and bit 1 determine the interrupt source, as indicated in Figure 3-1. Table 3-3 shows the relationship between an interrupt source and the values in the mode bits.

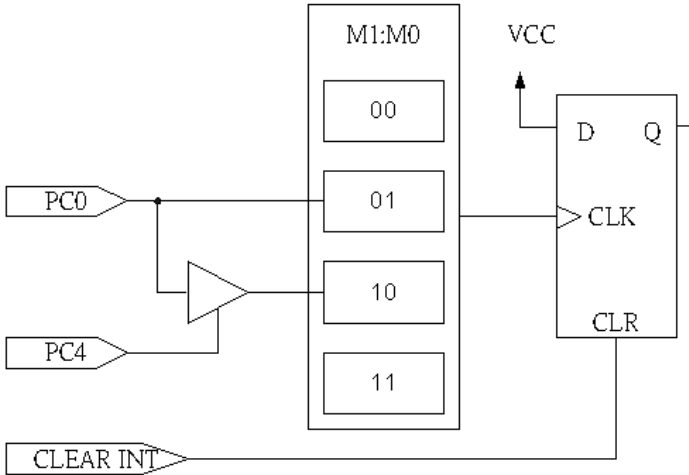

*Figure 3.1: Interrupt Sources*

*Table 3.3: Interrupt Mode Bit Values*

M1	M0	Description
0	0	Disable interrupt
0	1	Source = PC00
1	0	Source = PC00 & PC04
1	1	No used

### 3.3.3 Interrupt Triggering Edge Control

The interrupt can be triggered by a rising edge or a falling edge of the interrupt signal, selectable by the value written in the "triggering edge control" bit in the interrupt control register, as shown in Table 3.4.

*Table 3.4: Triggering Edge Control Bit Values*

E	Triggering edge of interrupt signal
1	Rising edge trigger
0	Falling edge trigger

### 3.3.4 Interrupt Flag Bit

The "interrupt flag" bit is a flag indicating the status of an interrupt. It is a readable and writable bit. Read the bit value to find the status of the interrupt, and write "1" to this bit to clear the interrupt. This bit must be cleared in the ISR to service the next incoming interrupt.

**Table 3.5: Interrupt Flag Bit Values**

F		Interrupt status
Read	1	Interrupt occurred
	0	No interrupt
Write	1	Clear interrupt
	0	Don't care

## 3.4 BoardID Switch

---

Read Base +36 can get the cards BoardID identifier. PCI-1757UP has a built-in SMD switch (SW1), which is used to define each card's unique identifier. You can determine this identity number in the register as shown in Table 3.6. If there are multiple cards in the same chassis, this BoardID setting is useful for identifying each card's device number. PCI-1757UP's BoardID switches have been set to 0 at the factory. If you need to adjust it to other numbers, set the SW1 by referring to the jumper and SMD switch setting.

**Table 3.6: BoardID Register**

Bit#	D7	D6	D5	D4	D3	D2	D1	D0
	X	X	X	X	ID3	ID2	ID1	ID0

ID0: the least significant bit (LSB) of Board ID

ID3: the most significant bit (MSB) of Board ID

X: ignore

APPENDIX  
**A**

## **Register Format**

# Appendix A Register Format

Base Address + n (Decimal)	Function	
	Read	Write
0	Port A	Port A
1	Port B	Port B
2	Port C	Port C
3	Configuration Register	Configuration Register
:	:	:
32	Interrupt Status Register	Interrupt Control Register
36	BoardID	N/A