



Table of Contents

1. Product Information	2
2. Electrical/Hardware Specifications	3
3. Order Information	17
4. Release Date.....	17

Product Information

DVP04AD-S2/DVP04DA-S2/DVP06XA-S2

The second generation DVP series slim analog modules are analog input modules, analog output modules, and input/output modules. Their features are described below.

- ✓ It is suggested that a second generation DVP series slim analog input module is used with an active transducer (a transducer is not connected to the power circuit which is connected to a system). If customers use a passive transducer (a transducer and a system are connected to a power circuit collectively), it is suggested that they use a first generation analog input module in that the characteristic of COM helps them save wiring cost.
- ✓ The analog interfaces of the second generation DVP series slim analog input modules DVP04AD-S2 and DVP06XA-S2 have better common mode noise rejection, but it needs to be noted that the COM terminals of the channels are independent. The COM terminals of the channels need to be wired independently.
- ✓ The second generation DVP series slim analog input/output modules provide complete power isolation and analog/digital isolation. Their noise immunity is improved. Besides, the second generation DVP series slim output modules provide more stable digital output values.

Application

- In order to meet the requirement of precise control, the stability of the second generation DVP series slim analog modules is improved. Besides, the control registers in the second generation DVP series slim analog modules are compatible with the first generation DVP series slim analog modules. Users can directly replace the first generation DVP series slim analog modules with the second generation DVP series slim analog modules.
- The second generation DVP series slim analog modules are designed to be widely used in various environments. If noise interferes with an analog input interface or power, especially a sensitive thermocouple, a pressure sensor, or a strain gauge, the complete differential input architecture of a second generation DVP series slim analog module can reject common mode noise. The second generation DVP series slim analog modules with power isolation and analog/digital isolation provide users with more stable digital values.
- The output terminals on DVP04DA-S2 are equipped with a Surge $\pm 500\text{V}$ /ESD Contact $\pm 6\text{KV}$ / ESD AIR $\pm 8\text{KV}$ protection ability. Besides, the stability of the output of DVP04DA-S2 is improved.
- DVP06XA-2S provides simple circuit control. It uses four analog input channels and two analog output channels to realize proportioning valve control.

Electrical/Hardware Specifications

Introduction of DVP04AD-S2

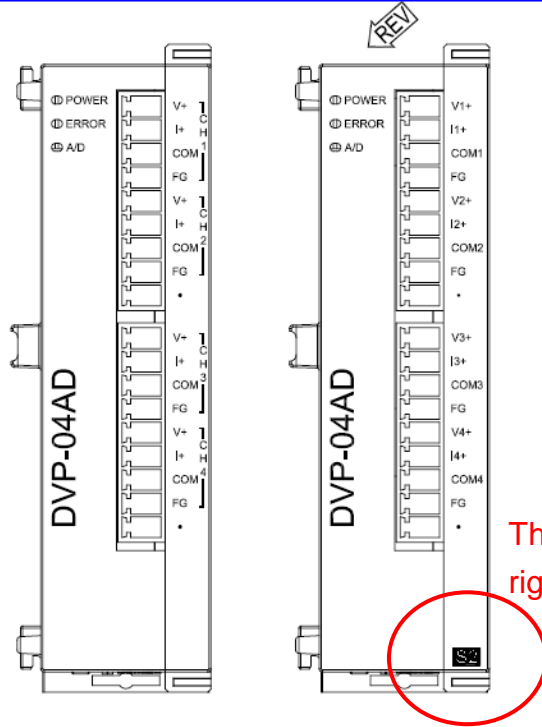

The mark "S2" is in the lower right corner of the module.

DVP04AD-S

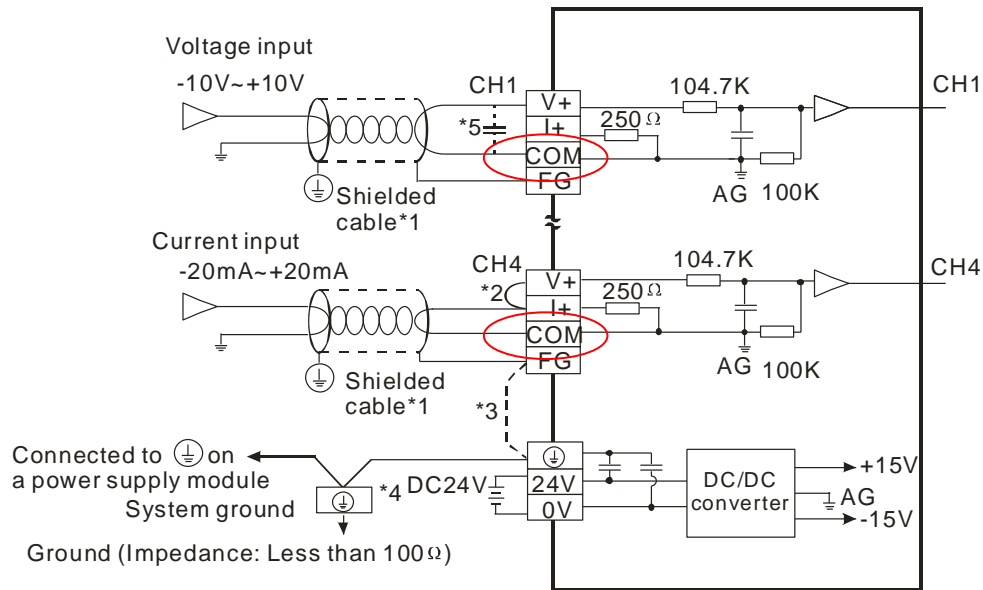

The negative poles of signals are connected to COM, and therefore the cost of wiring terminals is saved.

DVP04AD-S2

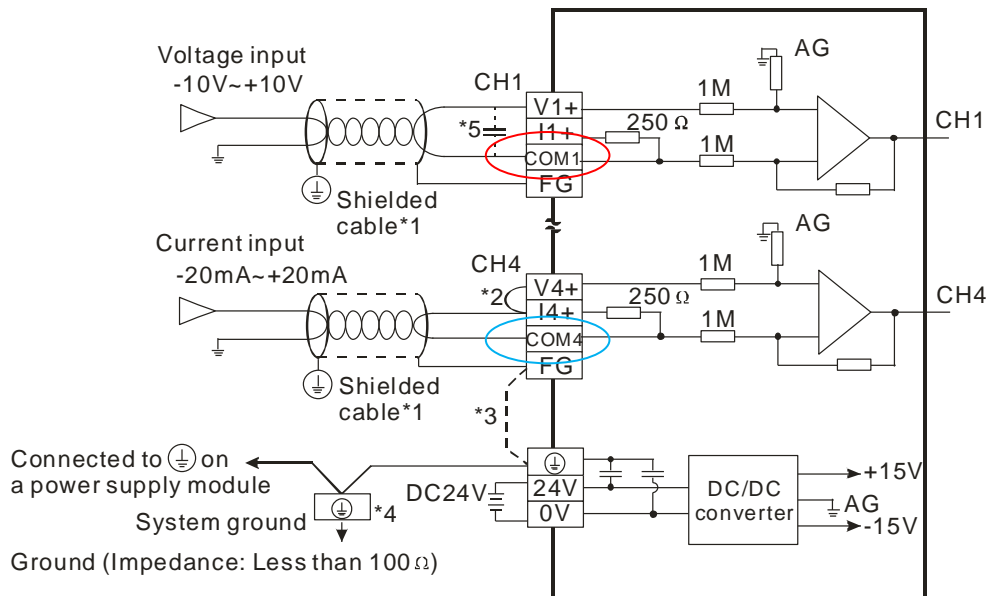

The channels are wired independently, and therefore the noise immunity of DVP04AD-S2 is increased.

- The comparison between DVP04AD-S and DVP04AD-S2 is shown below. Channel 1~channel 4 in DVP04AD-S use COM. Due to the differential hardware architecture of DVP04AD-S2, the channels need to be wired independently. Channel 1~channel 4 use COM1, COM2, COM3, and COM4 respectively.

DVP04AD-S:
The channels can be connected to COM.

DVP04AD-S	DVP04AD-S2
V+	V1+
I+	I1+
COM	COM1
FG	FG
V+	V2+
I+	I2+
COM	COM2
FG	FG
.	.
V+	V3+
I+	I3+
COM	COM3
FG	FG
V+	V4+
I+	I4+
COM	COM4
FG	FG
.	.

DVP04AD-S2:
The channels need to be wired independently.

Introduction of DVP04DA-S2

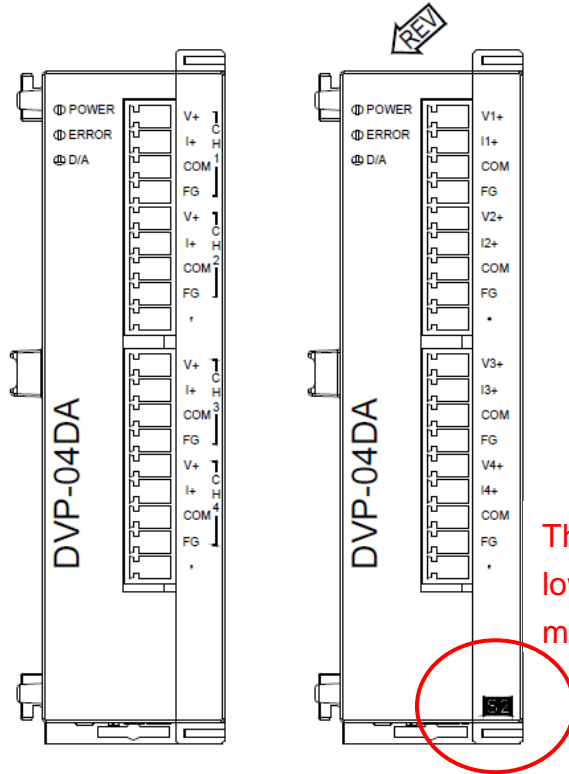

The mark "S2" is in the lower right corner of the module.

DVP04DA-S

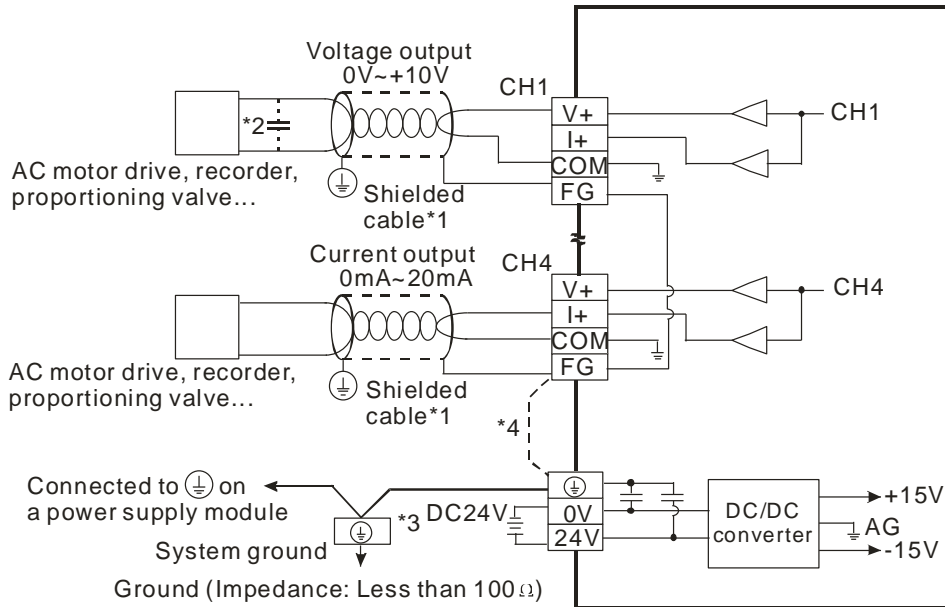

DVP04DA-S2 (DVP04DA-S2 is completely the same as DVP04DA-S. There is no difference in wiring.)

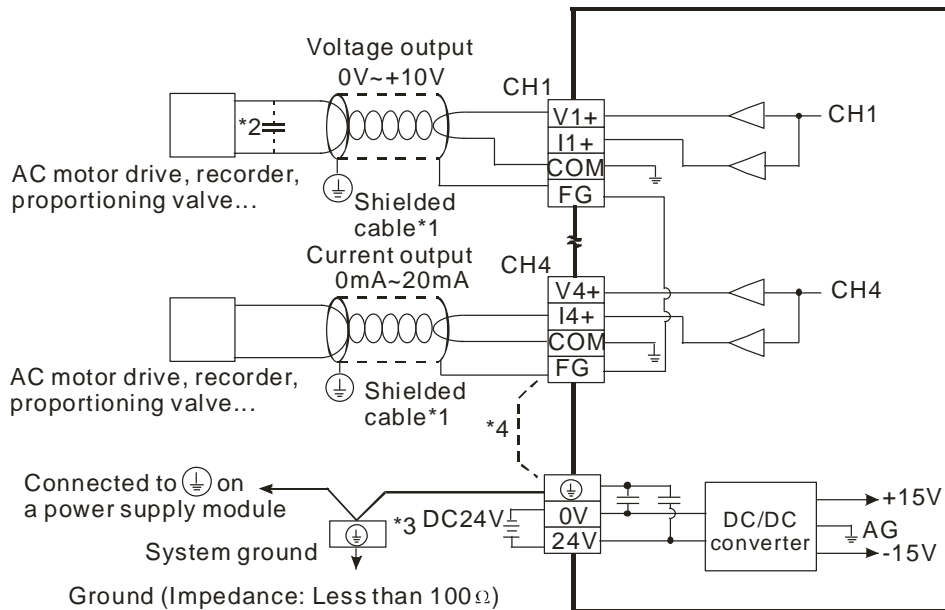

- There is no difference between DVP04DA-S and DVP04DA-S in terms of COM. The only difference between DVP04DA-S and DVP04DA-S is that the output channels in DVP04DA-S2 are marked with numbers so that users can wire the output channels correctly.

DVP04DA-S	DVP04DA-S2
V+	V1+
I+	I1+
COM	COM
FG	FG
V+	V2+
I+	I2+
COM	COM
FG	FG
.	.
V+	V3+
I+	I3+
COM	COM
FG	FG
V+	V4+
I+	I4+
COM	COM
FG	FG
.	.

DVP04DA-S & DVP04DA-S2: DVP04DA-S2 is completely the same as DVP04DA-S. There is no difference in wiring.

Introduction of DVP06XA-S2

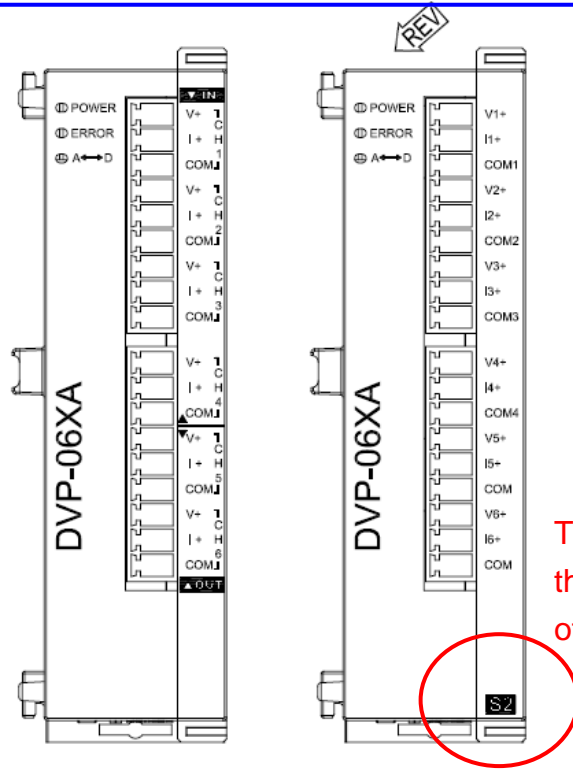

The mark "S2" is in the lower right corner of the module.

DVP06XA-S

Analog input

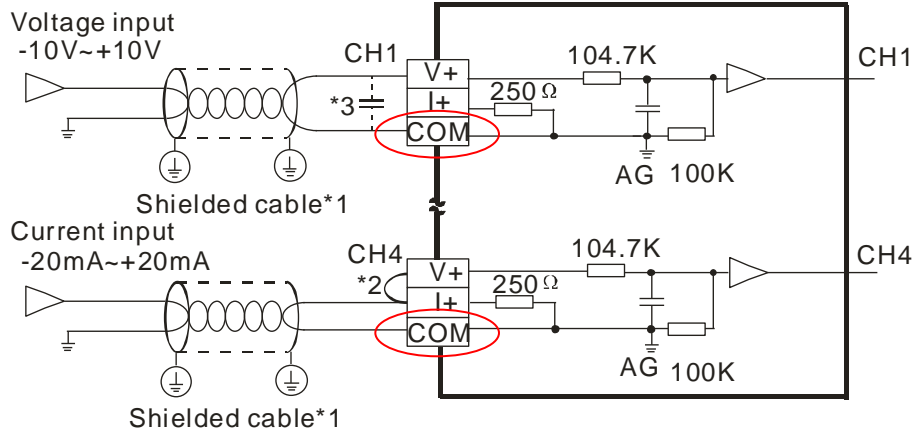

The negative poles of signals are connected to COM, and therefore the cost of wiring terminals is saved.

Analog output

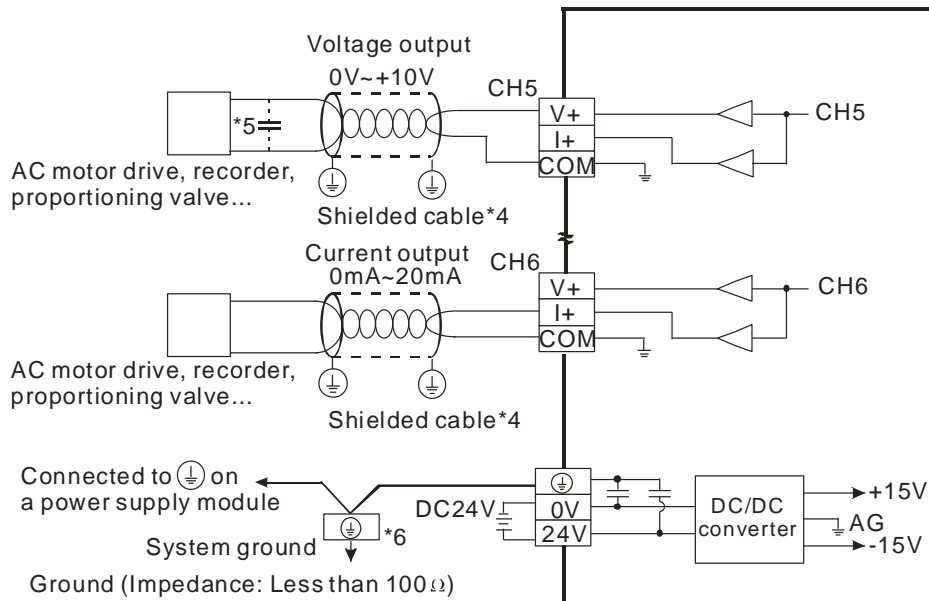

DVP06XA-S2

Analog input

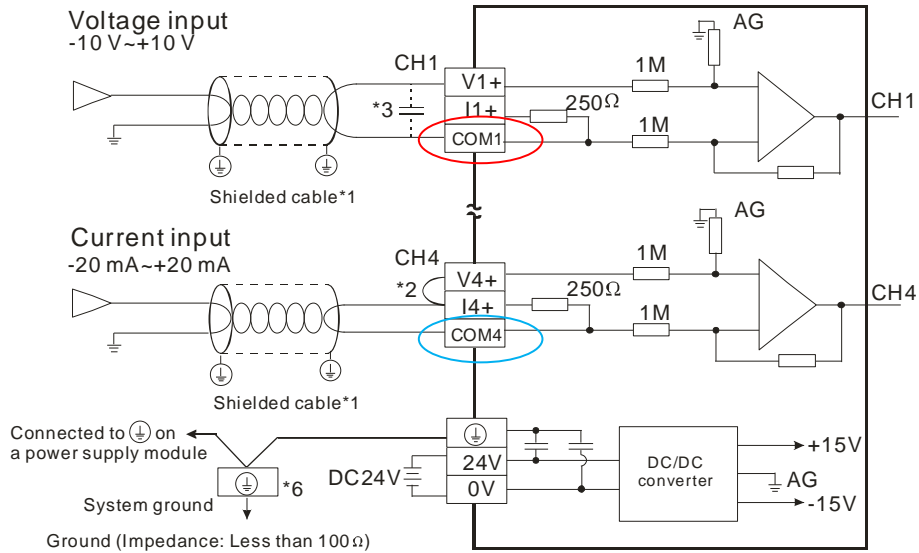

The channels are wired independently, and therefore the noise immunity of DVP06XA-S2 is increased.

Analog output (The analog output terminals on DVP06XA-S2 are completely the same as the analog output terminals on DVP06XA-S. There is no difference in wiring.)

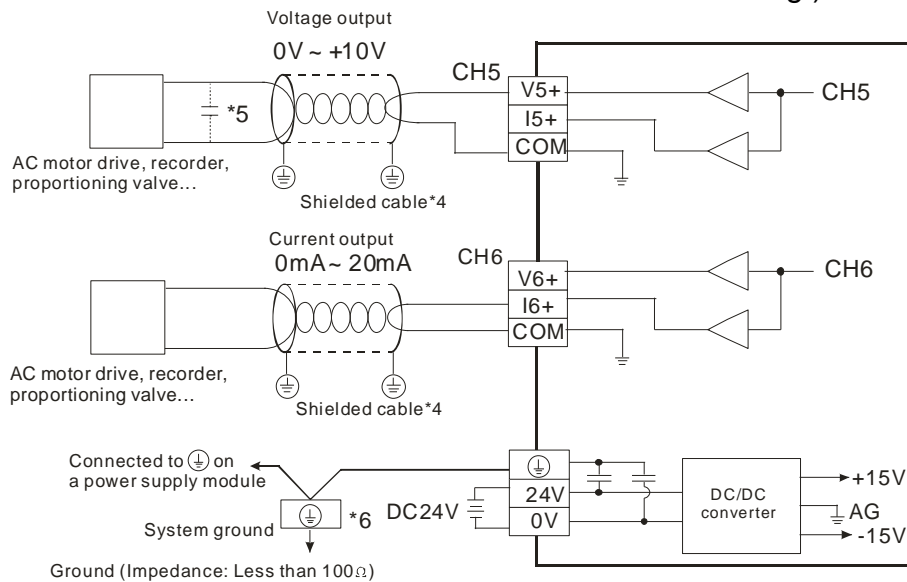

- The difference between DVP06XA-S and DVP06XA-S2 is shown below. Channel 1~channel 6 in DVP06XA-S use COM. Due to the hardware architecture of DVP06XA-S2, the analog input channels need to be wired independently. Channel 1~channel 4 use COM1, COM2, COM3, and COM4 respectively.

DVP06XA-S (analog input): The channels can be connected to COM.

DVP06XA-S	DVP06XA-S2
V+	V1+
I+	I1+
COM	COM1
V+	V2+
I+	I2+
COM	COM2
V+	V3+
I+	I3+
COM	COM3
V+	V4+
I+	I4+
COM	COM4
V+	V5+
I+	I5+
COM	COM
V+	V6+
I+	I6+
COM	COM

DVP06XA-S2 (analog input): The channels need to be wired independently.

DVP06XA-S & DVP06XA-S2 (analog output): The analog output terminals on DVP06XA-S2 are completely the same as the analog output terminals on DVP06XA-S. There is no difference in wiring.

● Electrical specifications for DVP04AD-S2

Analog/Digital (4A/D) module	Voltage input	Current input
Supply voltage	24 V DC (20.4 V DC~28.8 V DC) (-15%~+20%)	
Analog input channel	4 channels/module	
Analog input range	±10 V	±20 mA
Digital conversion range	±8,000	±4,000
Resolution	14 bits ($1_{LSB}=1.25\text{ mV}$)	13 bits ($1_{LSB}=5\text{ }\mu\text{A}$)
Input impedance	> 200 K Ω	250 Ω
Overall accuracy	25°C/77°F: The error allowed is ±0.5% of full scale. 0~55°C/32~131°F: The error allowed is ±1% of full scale.	
Response time	3 ms × Number of channels	
Isolation method	The analog circuit is isolated from the digital circuit by an optocoupler, and the analog channels are not isolated from one another.	
Absolute input range	±15 V	±32 mA
Digital data format	16-bit two's complement	
Average function	Yes (CR#2~CR#5 can be set. Range: K1~K20)	
Self-diagnosis	Upper and lower limit detection/channel	
Communication mode (RS-485)	ASCII/RTU mode Communication rate: 4,800/9,600/19,200/38,400/57,600/115,200 bps ASCII mode: 7 data bits, even parity bit, 1 stop bit (7, E, 1) RTU mode: 8 data bits, even parity bit, 1 stop bit (8, E, 1) If DVP04AD-S2 is connected to a PLC, the RS-485 communication can not be used.	
Connecting to DVP series PLCs	If DVP04AD-S2 modules are connected to a PLC, they will be numbered 0~7 according to their closeness to the PLC. Eight modules at most can be connected, and they do not occupy digital I/O points.	

● Electrical specifications for DVP04DA-S2

Digital/Analog (4D/A) module	Voltage output	Current output
Supply voltage	24 V DC (20.4 V DC~28.8 V DC) (-15%~+20%)	
Analog output channel	4 channels/module	
Analog output range	0~10 V	0~20 mA
Digital data range	0~4,000	0~4,000
Resolution	12 bits ($1_{LSB}=2.5$ mV)	12 bits ($1_{LSB}=5$ μ A)
Output impedance	0.5 Ω or less than 0.5 Ω	
Overall accuracy	25°C/77°F: The error allowed is $\pm 0.5\%$ of full scale. 0~55°C/32~131°F: The error allowed is $\pm 1\%$ of full scale.	
Response time	3 ms x Number of channels	
Maximum output current	10 mA (1 K Ω ~2 M Ω)	-
Permissible load impedance	-	0 ~ 500 Ω
Digital data format	16-bit two's complement	
Isolation method	The analog circuit is isolated from the digital circuit by an optocoupler, and the analog channels are not isolated from one another.	
Protection	The voltage output is equipped with a short circuit protection. If a short circuit lasts for long, the internal circuit may be damaged. The current output can be an open circuit.	
Communication mode (RS-485)	ASCII/RTU mode Communication rate: 4,800/9,600/19,200/38,400/57,600/115,200 bps ASCII mode: 7 data bits, even parity bit, 1 stop bit (7, E, 1) RTU mode: 8 data bits, even parity bit, 1 stop bit (8, E, 1) If DVP04AD-S2 is connected to a PLC, the RS-485 communication can not be used.	
Connecting to DVP series PLCs	If DVP04DA-S2 modules are connected to a PLC, they will be numbered 0~7 according to their closeness to the PLC. Eight modules at most can be connected, and they do not occupy digital I/O points.	

- Electrical specifications for DVP06XA-S2

Mixed analog/digital (A/D) module	Voltage input	Current input
Supply voltage	24 V DC (20.4 V DC~28.8 V DC) (-15%~+20%)	
Analog input channel	4 channels/module	
Analog input range	±10 V	±20 mA
Digital conversion range	±2,000	±1,000
Resolution	12 bits (1 _{LSB} =5 mV)	11 bits (1 _{LSB} =20 μA)
Input impedance	> 200 KΩ	250 Ω
Overall accuracy	25°C/77°F: The error allowed is ±0.5% of full scale. 0~55°C/32~131°F: The error allowed is ±1% of full scale.	
Response time	3 ms × Number of channels	
Isolation method	The analog circuit is isolated from the digital circuit by an optocoupler, and the analog channels are not isolated from one another.	
Absolute input range	±15 V	±32 mA
Digital data format	16-bit two's complement	
Average function	Yes (CR#2~CR#5 can be set. Range: K1~K20)	
Self-diagnosis	Upper and lower limit detection/channel	

Mixed analog/digital (A/D) module	Voltage output	Current output
Analog output channel	2 channels/module	
Analog output range	0~10 V	0~20 mA
Digital data range	0~4,000	0~4,000
Resolution	12 bits (1 _{LSB} =2.5 mV)	12 bits (1 _{LSB} =5 μA)
Overall accuracy	25°C/77°F: The error allowed is ±0.5% of full scale. 0~55°C/32~131°F: The error allowed is ±1% of full scale.	
Output impedance	0.5 Ω or less than 0.5 Ω	
Response time	3 ms × Number of channels	
maximum output current	10 mA (1 KΩ~2 MΩ)	-
Permissible load impedance	-	0~500 Ω
Digital data format	16-bit two's complement	
Isolation method	The analog circuit is isolated from the digital circuit by an optocoupler, and the analog channels are not isolated from one another.	
Protection	The voltage output is equipped with a short circuit protection. If a short circuit lasts for long, the internal circuit may be damaged. The current output can be an open circuit.	
Communication mode (RS-485)	Communication rate: 4,800/9,600/19,200/38,400/57,600/115,200 bps ASCII mode: 7 data bits, even parity bit, 1 stop bit (7, E, 1) RTU mode: 8 data bits, even parity bit, 1 stop bit (8, E, 1) If DVP04AD-S2 is connected to a PLC, the RS-485 communication can not be used.	
Connecting to DVP series PLCs	If DVP06XA-S2 modules are connected to a PLC, they will be numbered 0~7 according to their closeness to the PLC. Eight modules at most can be connected, and they do not occupy digital I/O points.	

● Other

Power	
Maximum power consumption	24 V DC (20.4 V DC~28.8 V DC) (-15%~+20%), 4 W, supplied by external power
Environment	
Operating/Storage environment	Operating environment: 0°C~55°C (temperature), 5~95% (humidity), pollution degree 2 Storage environment: -25°C~70°C (temperature), 5~95% (humidity)
Vibration/Shock resistance	International standards: IEC 61131-2, IEC 68-2-6 (TEST Fc)/IEC 61131-2 & IEC 68-2-27 (TEST Ea)

Order Information

DVP 06 XA - S2

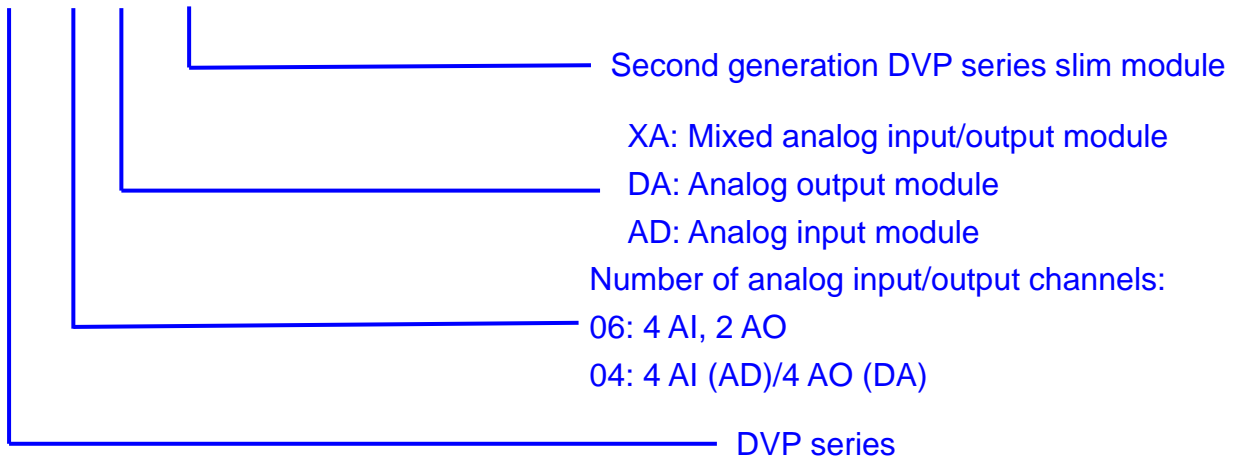

Release Date

Product name	Model	Date	Minimum quantity
Second generation DVP series slim analog input module	DVP04AD-S2	Jun 2015	6
Second generation DVP series slim analog output module	DVP04DA-S2		
Second generation DVP series mixed analog input/output module	DVP06XA-S2		